

**Bidirektionale zahnradpumpen BRT2 mit Flansch und ISO Gewinde
Bidirectional gear pumps BRT2 flange and shaft ISO**

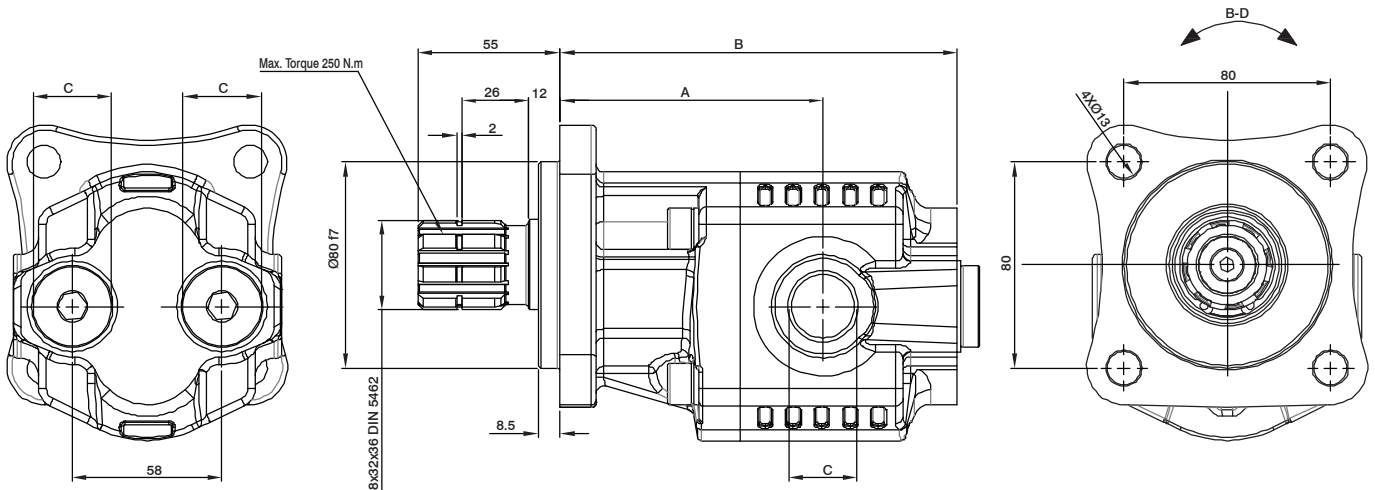

| Model | A | B |
|---------|-----|-----|
| BRT2006 | 90 | 125 |
| BRT2010 | 95 | 130 |
| BRT2016 | 96 | 140 |
| BRT2020 | 100 | 145 |
| BRT2025 | 103 | 154 |
| BRT2032 | 112 | 165 |
| BRT2040 | 125 | 178 |

Eigenschaften/Specifications

| Model | Fördervolumen bis Flow to 1.000 r.p.m. | Max.Dauerdruck Continuous pressure | Max. Intermittierend Intermittent Pressure | Max. Druckspitze Peak Pressure | Max. Dauergeschwindigkeit Continuous speed | Max. Geschwindigkeitsspitze Peak speed | Eingang Entry C | Ausgang Exit C | Gewicht Weight |
|---------|--|--|---|---|---|--|--------------------|-------------------|-------------------|
| BRT2006 | 6.1 ltrs./min | 280 Bar | 300 Bar | 330 Bar | 2.300 rpm | 3.100 rpm | 1/2" BSP | 1/2" BSP | 5,5 Kgs. |
| BRT2010 | 10 ltrs./min | 280 Bar | 300 Bar | 330 Bar | 2.300 rpm | 3.100 rpm | 1/2" BSP | 1/2" BSP | 5,8 Kgs. |
| BRT2016 | 16.2 ltrs./min | 280 Bar | 300 Bar | 330 Bar | 2.300 rpm | 3.100 rpm | 1/2" BSP | 1/2" BSP | 6 Kgs. |
| BRT2020 | 20.1 ltrs./min | 260 Bar | 280 Bar | 300 Bar | 2.300 rpm | 3.100 rpm | 1/2" BSP | 1/2" BSP | 6,5 Kgs. |
| BRT2025 | 25 ltrs./min | 220 Bar | 250 Bar | 270 Bar | 2.300 rpm | 3.100 rpm | 3/4" BSP | 3/4" BSP | 7 Kgs. |
| BRT2032 | 32.2 ltrs./min | 190 Bar | 200 Bar | 220 Bar | 2.100 rpm | 2.900 rpm | 3/4" BSP | 3/4" BSP | 7,5 Kgs. |
| BRT2040 | 40.3 ltrs./min | 180 Bar | 190 Bar | 200 Bar | 1.900 rpm | 2.600 rpm | 3/4" BSP | 3/4" BSP | 8 Kgs. |

Drehrichtung: bidirektional min.Geschwindigkeit:
Directional of rotation :Bidirectional minimum speed: 300 R.P.M.

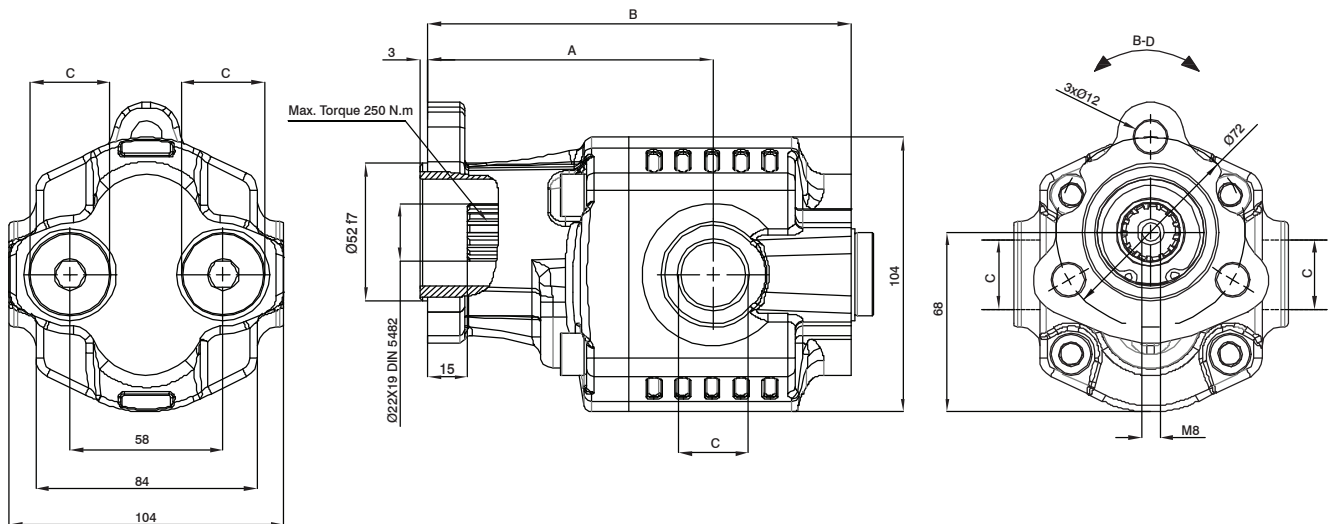
bidirektionale zahnradpumpen BRT2 mit Flansch und UNI Gewinde
Bidirectional gear pumps BRT2 Flange and shaft UNI

| Model | A | B |
|---------|-----|-----|
| BRT2206 | 96 | 130 |
| BRT2210 | 102 | 136 |
| BRT2216 | 102 | 146 |
| BRT2220 | 106 | 152 |
| BRT2225 | 108 | 160 |
| BRT2232 | 119 | 171 |
| BRT2240 | 132 | 184 |

Eigenschaften/Specifications

| Model | Fördervolumen bis Flow to 1.000 r.p.m. | Max. Dauerdruck Continuous pressure | Max. Intermittierend Intermittent Pressure | Max. Druckspitze Peak | Max. Dauergeschwindigkeit Continuous speed | Max. Geschwindigkeitsspitze Peak speed | Eingang Entry C | Ausgang Exit C | Gewicht Weight |
|---------|--|---|---|-----------------------------|---|--|--------------------|-------------------|-------------------|
| BRT2206 | 6.1 ltrs./min | 280 Bar | 300 Bar | 330 Bar | 2.300 rpm | 3.100 rpm | 1/2" BSP | 1/2" BSP | 5,5 Kgs. |
| BRT2210 | 10 ltrs./min | 280 Bar | 300 Bar | 330 Bar | 2.300 rpm | 3.100 rpm | 1/2" BSP | 1/2" BSP | 5,8 Kgs. |
| BRT2216 | 16.2 ltrs./min | 280 Bar | 300 Bar | 330 Bar | 2.300 rpm | 3.100 rpm | 1/2" BSP | 1/2" BSP | 6 Kgs. |
| BRT2220 | 20.1 ltrs./min | 260 Bar | 280 Bar | 300 Bar | 2.300 rpm | 3.100 rpm | 1/2" BSP | 1/2" BSP | 6,5 Kgs. |
| BRT2225 | 25 ltrs./min | 220 Bar | 250 Bar | 270 Bar | 2.300 rpm | 3.100 rpm | 3/4" BSP | 3/4" BSP | 7 Kgs. |
| BRT2232 | 32.2 ltrs./min | 190 Bar | 200 Bar | 220 Bar | 2.100 rpm | 2.900 rpm | 3/4" BSP | 3/4" BSP | 7,5 Kgs. |
| BRT2240 | 40.2 ltrs./min | 180 Bar | 190 Bar | 200 Bar | 1.900 rpm | 2.600 rpm | 3/4" BSP | 3/4" BSP | 8 Kgs. |

Drehrichtung: bidirektional min. Geschwindigkeit:
 Directional of rotation : Bidirectional minimum speed: 300 R.P.M.

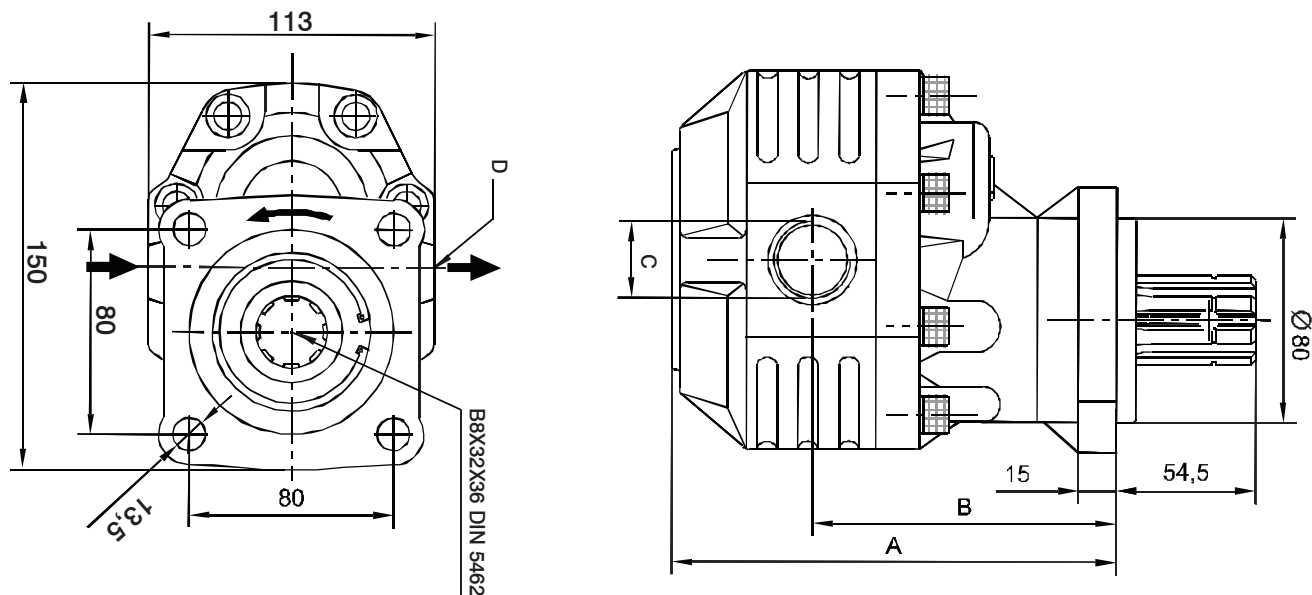
**bidirektionale zahnradpumpen BRT3 mit ISO Flansch und Gewinde
Bidirectional gear pumps BRT3 ISO flange and shaft**

| Model | A | B |
|---------|-------|-------|
| BRT3*17 | 163,5 | 114 |
| BRT3*27 | 171,5 | 117,5 |
| BRT3*34 | 174,5 | 119,5 |
| BRT3*43 | 182,5 | 123 |
| BRT3*51 | 187,5 | 124,5 |
| BRT3*61 | 188,5 | 127 |
| BRT3*82 | 203,5 | 133,5 |

Eigenschaften/Features

| Model | Fördervolumen bis Flow to 1.000 r.p.m. | Max.Dauerdruck Continuous pressure | Max. Intermittierend Intermittent Pressure | Max. Druckspitze Peak | Max. Dauergeschwindigkeit Continuous speed | Max. Geschwindigkeitsspitze Peak speed | Eingang Entry C | Ausgang Exit C | Gewicht Weight |
|---------|--|------------------------------------|--|-----------------------|--|--|-----------------|----------------|----------------|
| BRT3*17 | 17,2 ltrs./min | 290 Bar | 315 Bar | 315 Bar | 2.100 rpm | 2.800 rpm | 1/2" BSP | 1/2" BSP | 10,5 Kgs. |
| BRT3*27 | 26,5 ltrs./min | 290 Bar | 315 Bar | 315 Bar | 2.100 rpm | 2.800 rpm | 3/4" BSP | 3/4" BSP | 10,9 Kgs. |
| BRT3*34 | 34,3 ltrs./min | 280 Bar | 300 Bar | 300 Bar | 1.800 rpm | 2.600 rpm | 3/4" BSP | 3/4" BSP | 11,4 Kgs. |
| BRT3*43 | 43,7 ltrs./min | 270 Bar | 290 Bar | 290 Bar | 1.800 rpm | 2.300 rpm | 1" BSP | 3/4" BSP | 12 Kgs. |
| BRT3*51 | 51,4 ltrs./min | 240 Bar | 260 Bar | 260 Bar | 1.800 rpm | 2.300 rpm | 1" BSP | 1" BSP | 12,5 Kgs. |
| BRT3*61 | 60,8 ltrs./min | 220 Bar | 240 Bar | 240 Bar | 1.400 rpm | 1.800 rpm | 1" BSP | 1" BSP | 13 Kgs. |
| BRT3*82 | 81,1 ltrs./min | 190 Bar | 210 Bar | 210 Bar | 1.400 rpm | 1.800 rpm | 1"1/4 BSP | 1" BSP | 13,8 Kgs. |

Drehrichtung = BRT 30: Fahrplan / Rechts, BRT 31: Gegen den Uhrzeigersinn / Links, BRT 35: Bidirektional Mindestgeschwindigkeit: 300 R.P.M.
 Direction of Turn = BRT 30: Schedule / Right, BRT 31: Anti-clockwise / Left, BRT 35: Bidirectional Minimum speed: 300 R.P.M.

**Bidirektionale zahnradpumpen BRT3 mit ISO Flansch und Gewinde
Bidirectional gear pumps BRT3 ISO flange and shaft**

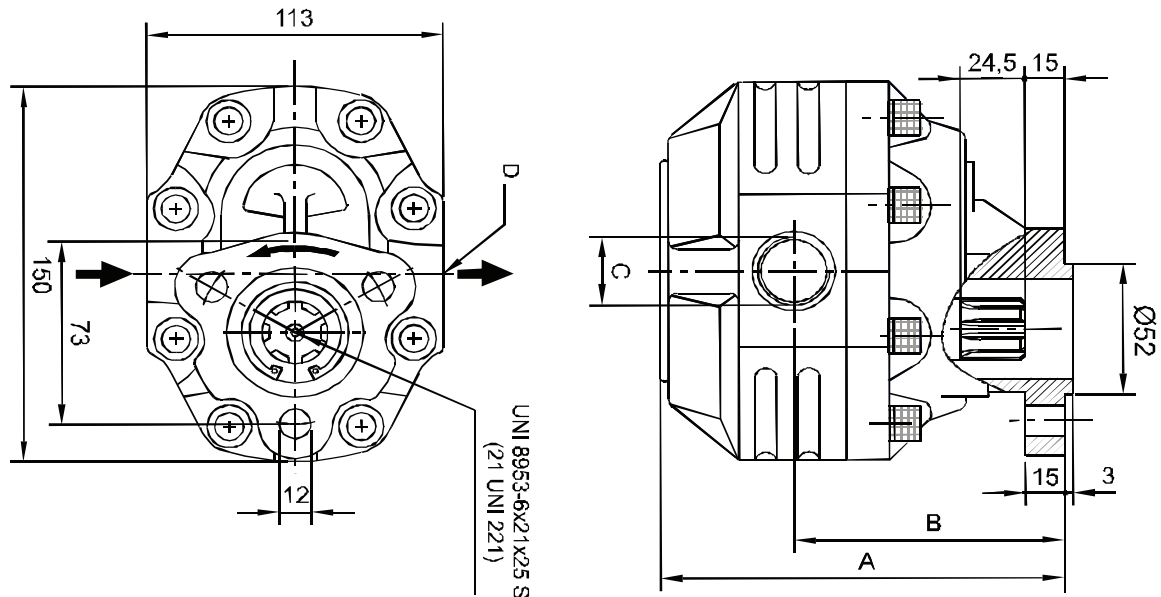

| Modelo | A | B |
|---------|-------|-------|
| BRT3*17 | 151,5 | 102 |
| BRT3*27 | 159,5 | 105,5 |
| BRT3*34 | 162,5 | 107,5 |
| BRT3*43 | 170,5 | 111 |
| BRT3*51 | 175,5 | 112,5 |
| BRT3*61 | 176,5 | 115 |
| BRT3*82 | 191,5 | 121,5 |

Eigenschaften/Features

| Model | Fördervolumen bis Flow to 1.000 r.p.m. | Max. Dauerdruck Continuous pressure | Max. Intermittierend Intermittent Pressure | Max. Druckspitze Peak | Max. Dauergeschwindigkeit Continuous speed | Max. Geschwindigkeitsspitze Peak speed | Eingang Entry C | Ausgang Exit C | Gewicht Weight |
|---------|--|---|---|-----------------------------|---|--|--------------------|-------------------|-------------------|
| BRT3*17 | 17,2 ltrs./min | 290 Bar | 315 Bar | 315 Bar | 2.100 rpm | 2.800 rpm | 1/2" BSP | 1/2" BSP | 8,5 Kgs. |
| BRT3*27 | 26,5 ltrs./min | 290 Bar | 315 Bar | 315 Bar | 2.100 rpm | 2.800 rpm | 3/4" BSP | 3/4" BSP | 9 Kgs. |
| BRT3*34 | 34,3 ltrs./min | 280 Bar | 300 Bar | 300 Bar | 1.800 rpm | 2.600 rpm | 3/4" BSP | 3/4" BSP | 9,5 Kgs. |
| BRT3*43 | 43,7 ltrs./min | 270 Bar | 290 Bar | 290 Bar | 1.800 rpm | 2.300 rpm | 1" BSP | 3/4" BSP | 10 Kgs. |
| BRT3*51 | 51,4 ltrs./min | 240 Bar | 260 Bar | 260 Bar | 1.800 rpm | 2.300 rpm | 1" BSP | 1" BSP | 10,5 Kgs. |
| BRT3*61 | 60,8 ltrs./min | 220 Bar | 240 Bar | 240 Bar | 1.400 rpm | 1.800 rpm | 1" BSP | 1" BSP | 11 Kgs. |
| BRT3*82 | 81,1 ltrs./min | 190 Bar | 210 Bar | 210 Bar | 1.400 rpm | 1.800 rpm | 1" 1/4 BSP | 1" BSP | 11,6 Kgs. |

Drehrichtung = BRT 32: Fahrplan / Rechts, BRT 33: Gegen den Uhrzeigersinn / Links, BRT 34: Bidirektionale Mindestgeschwindigkeit: 300 U / min.
 Direction of Turn = BRT 32: Schedule / Right, BRT 33: Anti-clockwise / Left, BRT 34: Bidirectional Minimum speed: 300 R.P.M.

Bidirektionale zahnradpumpen BRT3 mit Flansch und SAE B Gewinde
Bidirectional gear pumps BRT3 Flange and shaft SAE B

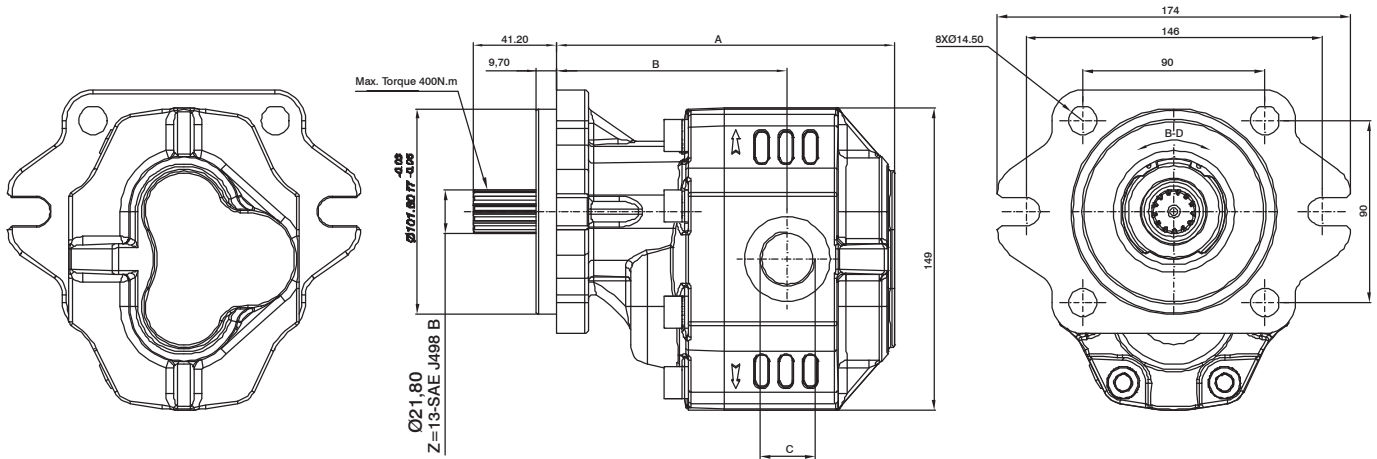

| Model | A | B |
|---------|-------|-------|
| BRT3*17 | 151,5 | 102 |
| BRT3*27 | 159,5 | 105,5 |
| BRT3*34 | 162,5 | 107,5 |
| BRT3*43 | 170,5 | 111 |
| BRT3*51 | 175,5 | 112,5 |
| BRT3*61 | 176,5 | 115 |
| BRT3*82 | 191,5 | 121,5 |

Eigenschaften/Features

| Model | Fördervolumen bis Flow to 1.000 r.p.m. | Max.Dauerdruck Continuous pressure | Max. Intermittierend Intermittent Pressure | Max. Druckspitze Peak | Max. Dauergeschwindigkeit Continuous speed | Max. Geschwindigkeitsspitze Peak speed | Eingang Entry C | Ausgang Exit C | Gewicht Weight |
|---------|--|--|---|-----------------------------|---|--|--------------------|-------------------|-------------------|
| BRT3717 | 17,2 ltrs./min | 290 Bar | 315 Bar | 315 Bar | 2.100 rpm | 2.800 rpm | 1/2" BSP | 1/2" BSP | 9 Kgs. |
| BRT3727 | 26,5 ltrs./min | 290 Bar | 315 Bar | 315 Bar | 2.100 rpm | 2.800 rpm | 3/4" BSP | 3/4" BSP | 9,5 Kgs. |
| BRT3734 | 34,3 ltrs./min | 280 Bar | 300 Bar | 300 Bar | 1.800 rpm | 2.600 rpm | 3/4" BSP | 3/4" BSP | 10 Kgs. |
| BRT3743 | 43,7 ltrs./min | 270 Bar | 290 Bar | 290 Bar | 1.800 rpm | 2.300 rpm | 1" BSP | 3/4" BSP | 10,5 Kgs. |
| BRT3751 | 51,4 ltrs./min | 240 Bar | 260 Bar | 260 Bar | 1.800 rpm | 2.300 rpm | 1" BSP | 1" BSP | 11 Kgs. |
| BRT3761 | 60,8 ltrs./min | 220 Bar | 240 Bar | 240 Bar | 1.400 rpm | 1.800 rpm | 1" BSP | 1" BSP | 11,5 Kgs. |
| BRT3782 | 81,1 ltrs./min | 190 Bar | 210 Bar | 210 Bar | 1.400 rpm | 1.800 rpm | 1"1/4 BSP | 1" BSP | 12 Kgs. |

Drehrichtung: Bidirektional
Mindestgeschwindigkeit: 300 R.P.M.
Direction of Turn: Bidirectional
Minimum speed: 300 R.P.M.

BRT3*17

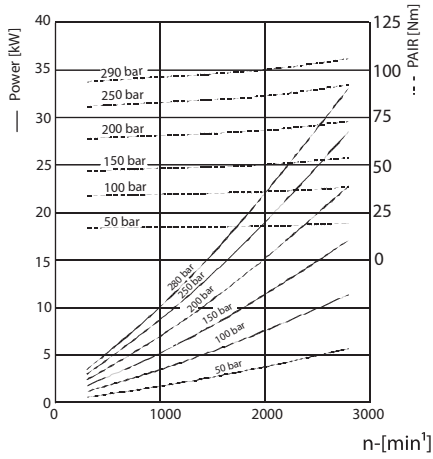

BRT3*27

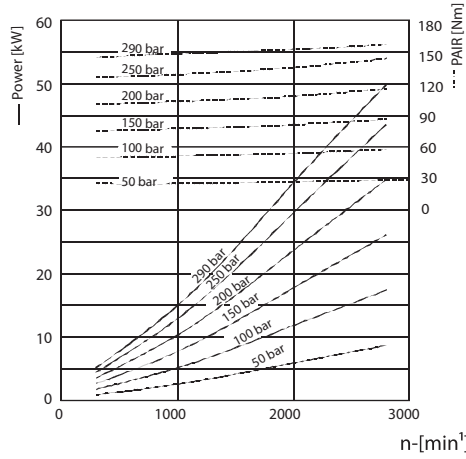

BRT3*34

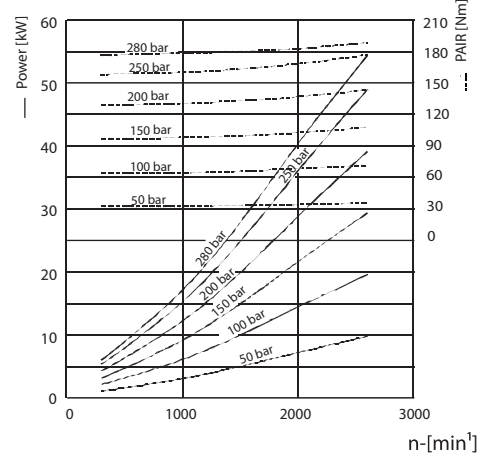

BRT3*43

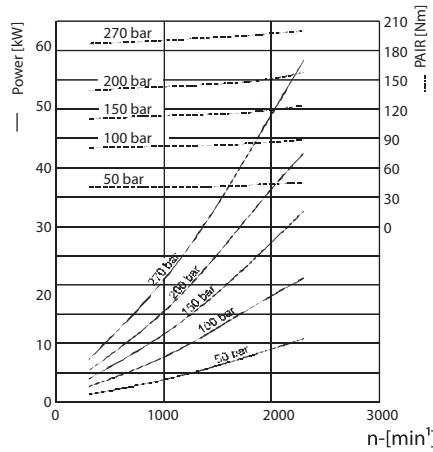

BRT3*51

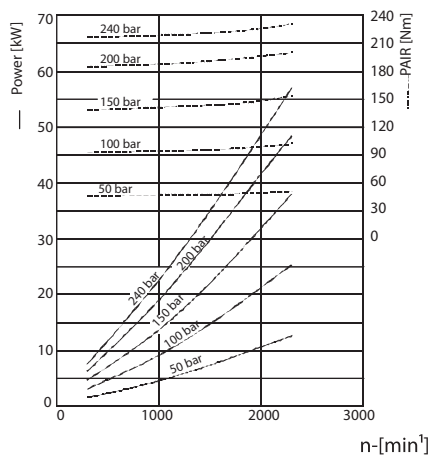

BRT3*61

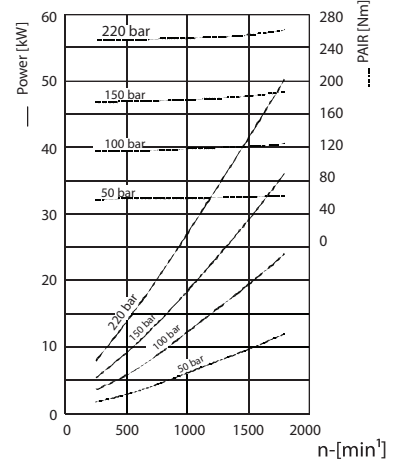

BRT3*82

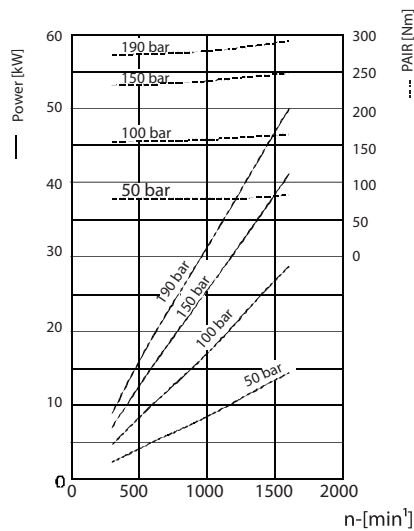

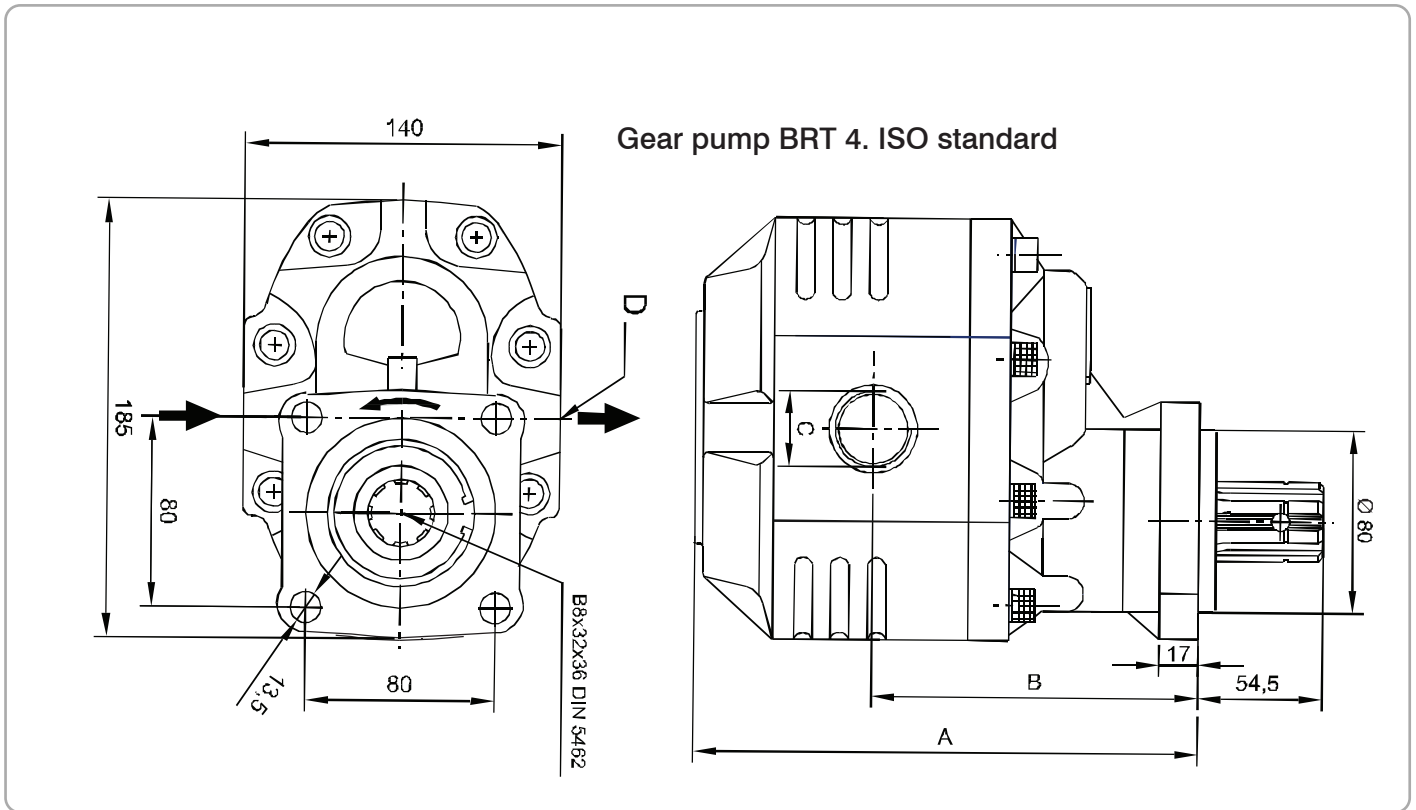

| Model | A | B |
|----------|-----|-------|
| BRT4*63 | 201 | 135 |
| BRT4*73 | 204 | 137 |
| BRT4*87 | 210 | 141 |
| BRT4*109 | 217 | 145 |
| BRT4*133 | 227 | 149 |
| BRT4*151 | 234 | 151,5 |

Eigenschaften/Features

| Model | Fördervolumen bis Flow to 1.000 r.p.m. | Max. Dauerdruck Continuous pressure | Max. Intermittierend Intermittent Pressure | Max. Druckspitze Peak | Max. Dauergeschwindigkeit Continuous speed | Max. Geschwindigkeitsspitze Peak speed | Eingang Entry C | Ausgang Exit C | Gewicht Weight |
|---------|--|-------------------------------------|--|-----------------------|--|--|-----------------|----------------|----------------|
| BRT4*63 | 60,6 ltrs./min | 290 Bar | 315 Bar | 315 Bar | 1.700 rpm | 2.600 rpm | 1" BSP | 3/4" BSP | 16,3 Kgs. |
| BRT4*73 | 71,7 ltrs./min | 280 Bar | 300 Bar | 300 Bar | 1.700 rpm | 2.600 rpm | 1" BSP | 3/4" BSP | 16,8 Kgs. |
| BRT4*87 | 85,5 ltrs./min | 260 Bar | 280 Bar | 280 Bar | 1.700 rpm | 2.600 rpm | 1"1/4" BSP | 1" BSP | 17,3 Kgs. |
| BRT4*10 | 107,5 ltrs./min | 240 Bar | 260 Bar | 260 Bar | 1.700 rpm | 2.600 rpm | 1"1/4 BSP | 1" BSP | 18,5 Kgs. |
| BRT4*13 | 132,4 ltrs./min | 220 Bar | 250 Bar | 250 Bar | 1.400 rpm | 2.600 rpm | 1"1/4 BSP | 1" BSP | 19,8 Kgs. |
| BRT4*15 | 148,9 ltrs./min | 180 Bar | 210 Bar | 210 Bar | 1.400 rpm | 2.400 rpm | 1"1/4 BSP | 1" BSP | 20,3 Kgs. |

* = Direction of Turn = 0: Schedule / Right, 1: Anti-clockwise / Left

Gear pump BRT 4.Norma UNI

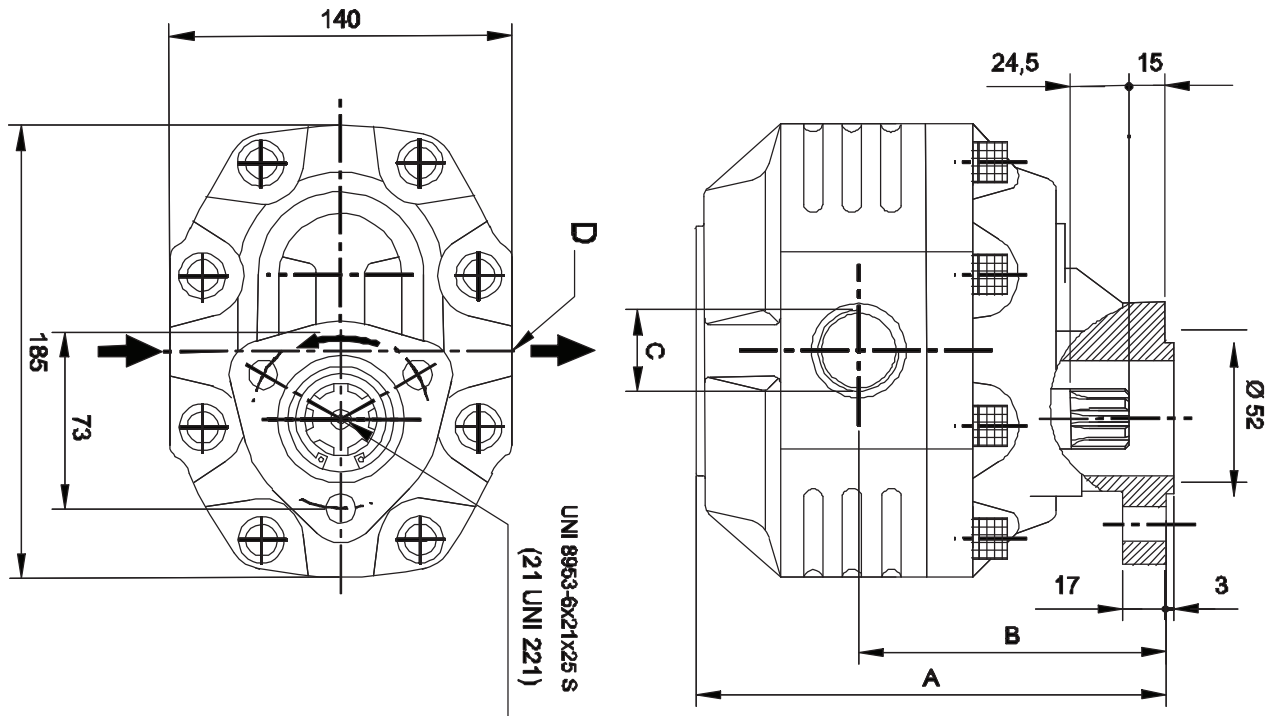

| Model | A | B |
|----------|-------|-------|
| BRT4*63 | 190,5 | 124,5 |
| BRT4*73 | 193,5 | 126,5 |
| BRT4*87 | 199,5 | 130,5 |
| BRT4*109 | 206,5 | 134,5 |
| BRT4*133 | 216,5 | 138,5 |
| BRT4*151 | 223,5 | 141 |

Eigenschaften/Features

| Model | Fördervolumen bis Flow to 1.000 r.p.m. | Max. Dauerdruck Continuous pressure | Max. Intermittierend Intermittent Pressure | Max. Druckspitze Peak | Max. Dauergeschwindigkeit Continuous speed | Max. Geschwindigkeitsspitze Peak speed | Eingang Entry C | Ausgang Exit C | Gewicht Weight |
|---------|--|-------------------------------------|--|-----------------------|--|--|-----------------|----------------|----------------|
| BRT4*63 | 60,6 ltrs./min | 290 Bar | 315 Bar | 315 Bar | 1.700 rpm | 2.600 rpm | 1" BSP | 3/4" BSP | 16,1 Kgs. |
| BRT4*73 | 71,7 ltrs./min | 280 Bar | 300 Bar | 300 Bar | 1.700 rpm | 2.600 rpm | 1" BSP | 3/4" BSP | 16,5 Kgs. |
| BRT4*87 | 85,5 ltrs./min | 260 Bar | 280 Bar | 280 Bar | 1.700 rpm | 2.600 rpm | 1"1/4" BSP | 1" BSP | 17 Kgs. |
| BRT4*10 | 107,5 ltrs./min | 240 Bar | 260 Bar | 260 Bar | 1.700 rpm | 2.600 rpm | 1"1/4 BSP | 1" BSP | 18 Kgs. |
| BRT4*13 | 132,4 ltrs./min | 220 Bar | 250 Bar | 250 Bar | 1.400 rpm | 2.600 rpm | 1"1/4 BSP | 1" BSP | 19,5 Kgs. |
| BRT4*15 | 148,9 ltrs./min | 180 Bar | 210 Bar | 210 Bar | 1.400 rpm | 2.400 rpm | 1"1/4 BSP | 1" BSP | 20 Kgs. |

* = Direction of Turn = 2: Schedule / Right, 3: Anti-clockwise / Left

BRT4*63

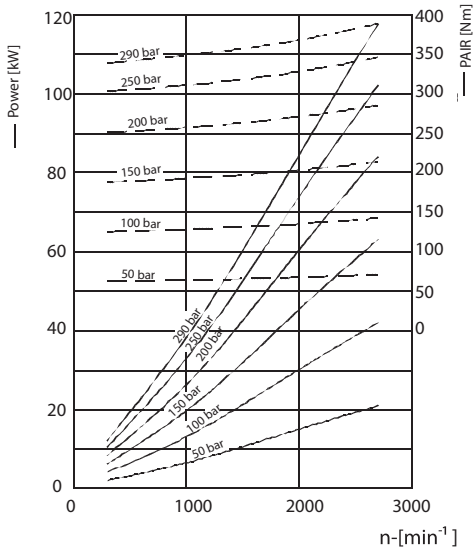

BRT4*73

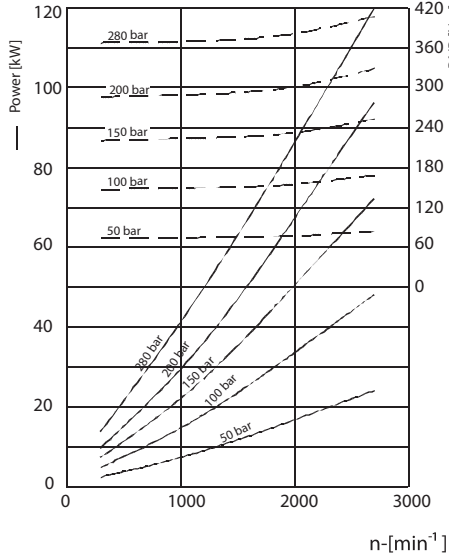

BRT4*87

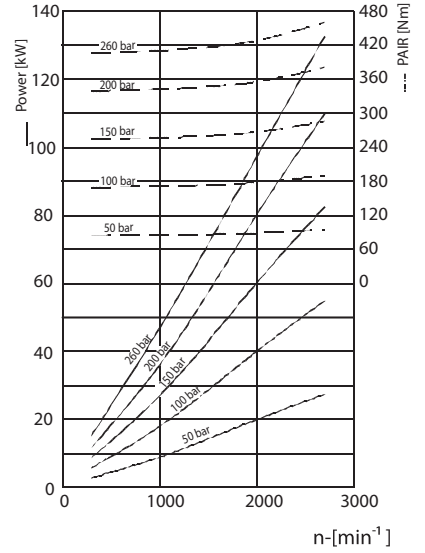

BRT4*10

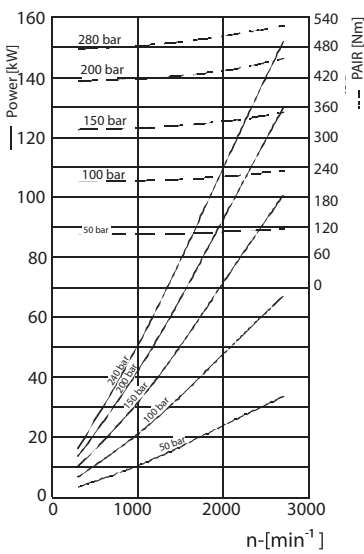

BRT4*13

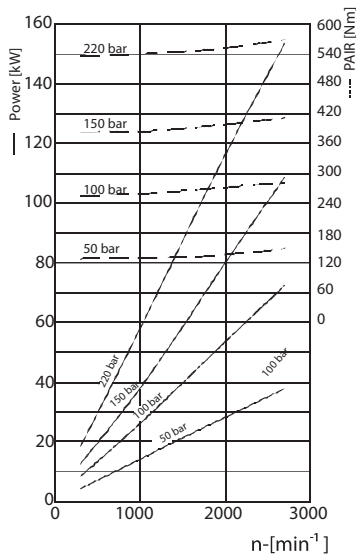

BRT4*15

